

MIMO2+, Multiple Input – Multiple Output Module User Manual



INTRODUCTION

The MIMO2+ (Multiple Input - Multiple Output) Module is an interface / bridge module that has two voltage inputs and two dry contact relays. The MIMO2+ is a Security Enabled Z-Wave™ Plus Wireless device compatible with other Z-Wave™ certified products.

SPECIFICATIONS

Power:	12 to 16 volts DC from regulated Power supply @~ 500mA capability
Frequency Range:	908.4MHz (US); 868.4MHz (EU)
Distance Range:	Max 100ft line of sight in unobstructed environment
PCB Size (LxW):	3.55" (90.2mm) x 3.3" (84mm)
Enclosure Size (LxWxD):	3.8" (96.5mm) x 3.8" (96.5mm) x 1.15" (29.3mm)
Weight:	6 OZ (170 gram)
Operating Temperature:	-10°C (14F) to +70°C (158F)

Input Signals 1, 2 (SIG1 & SIG2): Digital or Analog Input 0 to 6V DC. The trigger levels and hysteresis can be set independently via the Configuration Command Class for each input.

Input Signal Impedance: Z=66 ohm at 10KHz (for SIG1 or SIG2). This impedance is = 66 ohm = 34 ohm + j 540uH.

Output Relays 1, 2 (REL1 & REL2): SPDT, Max. Switching power of 120W; 10uA to 10A; High Dielectric strength coil-contacts: 1,000 VAC; Open contacts: 750 VAC; Conforms to FCC Part 68 requirements; Ag + Au clad bifurcated contacts fully sealed.

System Requirement: Any Z-Wave™ -enabled network and controller.



WARNINGS AND PRECAUTIONS

- **The dry contact relays are not capable of supporting higher-than-specified loads. Exceeding the specified switching power will cause damage to the unit and may cause damage to property and/or personal injury, including loss-of-life.**
 - **WARNING – Do not attempt to use the relays to switch residential or industrial Alternating Current (AC) lines. The relays are to be used for low-power load control only. Refer to above electrical specifications for relays.**
- **Do not store highly flammable items such as oily rags or other combustibles near your MIMO2+.**
- **Do not apply electrical power to the unit unless the unit is fully assembled.**
- **Install unit in accordance with electrical codes and regulations. In case you are unsure about any parts of these instructions consult an electrician or Z-Wave™ home automation specialist.**
- **Disconnect power source before working on or servicing the unit. Failure to do so could result in personal injury.**
- **Eye protection should be worn while installing or servicing the system. Failure to do so could result in personal injury.**
- **MIMO2+ functionality is based on wireless (RF) transmissions. Any wireless transmission can be subject to RF interference or loss-of-communication. This interference or loss-of-communication may cause the unit to not operate as intended. You, the end-user, are responsible for ensuring that the MIMO2+ functionality and installation meets your desired requirements.**

MIMO2+, Multiple Input – Multiple Output Module User Manual



○ **WARNING - The MIMO2+ must not be used in life support and / or safety applications.**

- Do not place MIMO2+ on or near metal objects. This decreases range and/or blocks wireless transmissions.
- Information provided in this manual is for your convenience and may be superseded by updates. The specifications and this manual are subject to change without notice. It is your responsibility to ensure that the MIMO2+ functionality meets your needs and specifications.

OVERVIEW

The MIMO2+ module provides two voltage inputs and two relay outputs (either can be wired normally open or normally closed). Z-Wave™ messages can be used to read the inputs and control the outputs. The inputs are very configurable for different trigger conditions and can even be mapped to control the outputs. The module includes a button for Z-Wave™ inclusion/exclusion and an LED for various status indications. The functionality of the SIG1 and SIG2 inputs is:

- Analog Triggering: Various trigger conditions can be set for high-to-low and low-to-high transitions. This provides great flexibility for capturing digital or analog events in a wide variety of applications. The trigger status can be automatically sent to the controller.
- Associations: Each input can be associated with up to two other Z-Wave™ devices, so that, for example, an associated device will automatically turn on (or off) based on the occurrence of a trigger event.
- Voltage Reporting: The analog input voltage levels can also be sent to the controller.

The physical outputs are relays that are typically activated by Z-Wave™ commands. However, the user can override Z-Wave™ control by configuring the input trigger conditions to be mapped to the output relays via logical AND/OR functions.

DIAGRAM

The MIMO2+ features two inputs and two outputs (in the form of relays). Wire connections can be made to the Normally Open (NO) or Normally Closed (CO) relay terminals. Control and monitoring is available via Z-Wave™ transmissions. The diagram below shows the major components of the MIMO2+ system.

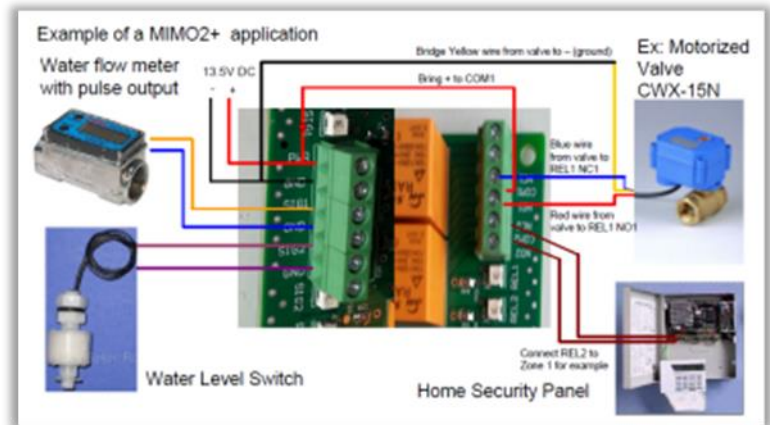
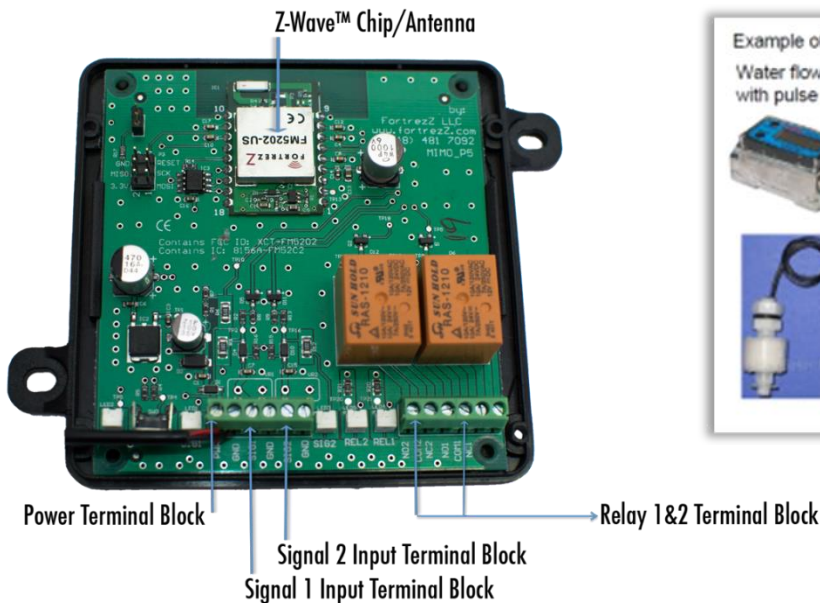

COMMON APPLICATIONS

- TEMPERATURE PROBES
- FLOAT SWITCHES / LEVEL SENSORS
- REED SWITCHES
- DOOR BELL BUTTONS
- MOTORIZED GATES / GARAGE DOORS
- SECURITY PANEL ZONE-IN
- MOTORIZED SHADES / PANELS / SOLAR
- EXISTING WIRED SECURITY SENSORS
- SOLENOID CONTROL



MIMO2+, Multiple Input – Multiple Output Module User Manual



USING THE MIMO2+ IN A Z-NETWORK

INCLUSION in (adding to) a network: 1) Set up the inclusion mode at the controller (for detailed directions, please refer to your controller user manual); 2) Briefly press the button once and the controller will indicate that the unit has been included in the network. Also, the Status LED will blink when the inclusion completes. *Inclusion and exclusion are always done at normal transmit power mode. This product can be included and operated in any Z-Wave network with other Z-Wave certified devices from other manufacturers and/or other applications. All non-battery operated nodes within the network will act as repeaters regardless of vendor to increase reliability of the network.*

EXCLUSION from (removing from) a network: 1) Set up the exclusion mode at the controller (for detailed directions, please refer to your controller user manual); 2) Press the button and the controller will indicate the unit has been removed from the network. The Status LED will blink when the exclusion completes.

ASSOCIATIONS: Once in a network, your controller can be used to associate the MIMO2+ inputs with other devices in the Z-Wave™ network, such as a light or remote audible alarm. For example, when an input is triggered, the MIMO2+ will automatically send a command to turn on the device(s) associated with that input. *Refer to your controller's documentation on how to associate the MIMO2+ with another device in your network.* Each input in the MIMO2+ supports one association group with a maximum of 2 associated devices in each group. The association groups and functionality are listed below for each endpoint of this Multichannel Device. The Lifeline associations should be automatically set up by your controller if it is Z-Wave™ Plus compatible. Refer to the MIMO2+ Technical Appendix for other configuration details.

Endpoint	Association Group (Name)	Maximum Number of Associations per Group	Supported Events (Command Classes)
0 (Root)	1 (Lifeline – the controller should automatically set up this association)	2	<ul style="list-style-type: none"> Device Reset Locally (via a 15 second hold of the program button) SIG1 (Multilevel Sensor Report, Multichannel) - upon change-of-trigger or periodically (Default: every 20 minutes) SIG2 (Multilevel Sensor Report, Multichannel) - upon change-of-trigger or periodically (Default: every 20 minutes) REL1 (Binary Switch Report, Multichannel) - upon change (Z-Wave™ command, auto-unlatch, or relay-mapping change) REL2 (Binary Switch Report, Multichannel) - upon change (Z-Wave™ command, auto-unlatch, or relay-mapping change)
	2 (SIG1 Trigger)	2	SIG1 (Basic Set) - upon change-of-trigger
	3 (SIG2 Trigger)	2	SIG2 (Basic Set) - upon change-of-trigger
1, 2 (SIG1, SIG2)	1 (Lifeline – the controller should automatically set up this association)	2	One of the following, depending on whether Endpoint 1 or Endpoint 2: <ul style="list-style-type: none"> SIG1 (Multilevel Sensor Report, Multichannel) - upon change-of-trigger or periodically (Default: every 20 minutes) SIG2 (Multilevel Sensor Report, Multichannel) - upon change-of-trigger or periodically (Default: every 20 minutes)
	2	2	One of the following, depending on whether Endpoint 1 or Endpoint 2: <ul style="list-style-type: none"> SIG1 (Basic Set) - upon change-of-trigger SIG2 (Basic Set) - upon change-of-trigger
3, 4 (REL1, REL2)	1 (Lifeline – the controller should automatically set up this association)	2	One of the following, depending on whether Endpoint 3 or Endpoint 4: <ul style="list-style-type: none"> REL1 (Binary Switch Report, Multichannel) - upon change (Z-Wave™ command, auto-unlatch, or relay-mapping change) REL2 (Binary Switch Report, Multichannel) - upon change (Z-Wave™ command, auto-unlatch, or relay-mapping change)

OTHER PROGRAM BUTTON PRESS ACTIONS: As mentioned above, the program button can be pressed once to include or exclude the MIMO2+ from a network. The following button press sequences can also be performed.

- Device Reset to Factory Defaults – Press and hold the program button for 15 seconds and then release. This can be done while the device is either in or out of a network. **CAUTION – When this is done in-network, the device will no longer be in the network and all configurations and associations will be set to default. Please use this procedure only in the event that your network primary controller is missing or otherwise inoperable.**
- Enter Over-the-Air (OTA) Firmware Update mode – Quickly press the program button 3 times while in-network. **Warning – This should not be done unless a firmware update will be immediately started at the controller. Do not allow the OTA mode to continue indefinitely without starting the firmware update at your controller.** Refer to your controller's manual for update procedures. Press the button once to exit the OTA mode.
- Send a Node Information frame to the network – Press the button once while in-network. Input and relay status messages are also sent shortly after the button press.

STATUS INDICATIONS: The MIMO2+ provides a status light to indicate various situations. As shown in the table below, the light blinks a variable number of times, fast or slow, periodically or only once.

MIMO2+, Multiple Input – Multiple Output Module User Manual



Fast Blinks	Slow Blinks	Periodic?	Description
1		Yes	Network-Wide Inclusion Mode (automatically entered at power-up when not 'in-network')
2			MIMO2+ is 'in-network' (indication after inclusion and after power up)
4		Yes	MIMO2+ is not 'in-network' (indication after button is pressed during NWI mode without inclusion or after 30 second timeout from NWI mode)
	3	Yes	Waiting for Over-The-Air firmware update (initiated by quickly pressing the program button 3 times; exit by another button press)

Z-Wave™ CONTROLLERS FOR MIMO2+

A Security-enabled controller *must* be used to fully utilize the product. Some older Z-Wave™ controllers may not be able to fully support the MultiChannel Command Class that is used by the MIMO2+ to address the 4 channels or Endpoints (see Technical Appendix). The MIMO2+ may still be able to be used with these controllers; however, some MIMO2+ features may not be configurable or used. An overview of the functionality available with these 'simple' controllers follows. For these controllers, the configuration commands are generally used to configure input SIG1 or output relay 1.

Reduced MIMO Functionality with 'Simple' Z-Wave™ Controllers

- Input SIG1 can be queried for level (via Multilevel Sensor Command Class)
- Relay 1 can be set or cleared or queried (via Basic or Binary Switch Command Class)

Z-Wave™ controllers that are capable of sending and receiving Multi-Channel Command Class messages allow the full MIMO2+ functionality to be configured and used. Using the MIMO2+ with these 'smart' controllers provides the greatest flexibility for the largest number of applications. The following is the mapping used for these 'smart' controllers.

MIMO2+ Input/Output Channel	Multi-Channel Endpoint
SIG1 (Input 1)	Endpoint 1
SIG2 (Input 2)	Endpoint 2
Relay1	Endpoint 3
Relay2	Endpoint 4

'Smart' Controllers can also be used to change various MIMO2+ operational parameters (Relay momentary vs latching, input-to-relay mapping, input triggering ranges/thresholds, and input level association reporting characteristics). Refer to the Technical Appendix for factory defaults and details on changing these configurations.

INPUT ANALOG TO DIGITAL CHARACTERISTICS (SIG1 and SIG2)

The input signal voltage conversion to Multilevel Sensor Command Class value is non-linear. A typical conversion curve (Voltage to ADC reading) is shown in the Technical Appendix. These are the values used for triggering and which are returned via the Multilevel Sensor report in response to a Multilevel Sensor Get request for a specific Endpoint. The conversion is a 12-bit conversion which allows values from 0 to 4095.

INPUT CONFIGURATION

SIG1 and SIG2 (Endpoints 1 and 2)

The default trigger configuration for the analog inputs, SIG1 and SIG2, simulates a Digital threshold around 1.6V (voltage falling) or 2V (voltage rising). That is, the inputs will trigger when the input is untriggered and the level goes above approximately 2V and will reset when the level is triggered and the level goes below approximately 1.6V. The trigger ranges and setups for SIG1 and SIG2 are very flexible and can be changed to meet many application requirements. Refer to the Technical Appendix for details. ADC count (corresponding to input voltages) reporting is automatically set up to the lifeline (controller) as described in the Associations section above.

Input-to-Relay Mapping

MIMO2+ can be configured to automatically turn a relay on/off when inputs are triggered or untriggered. The Configuration Command Class (Parameters 1 and 2) is used to set this mapping *for each Relay Output* (See Technical Appendix). **CAUTION: When input-to-relay mappings are enabled, Z-Wave™ commands to set or clear a relay are ignored.** The default for each relay is no input-to-relay mappings.

OUTPUT CONFIGURATION

For the default latching types, both relays (REL1 and REL2) are configured as momentary with a default latch time of 500msec. These can be changed with the Configuration Command Class (Parameters 1 and 2) as described in the Technical Appendix. A Basic Set or Binary Switch command with valid on/off values will set or clear *only* REL1 while the same Multichannel-encapsulated commands with valid on/off values can be used to set or clear *either* REL1 (Endpoint 3) or REL2 (Endpoint 4).

MIMO2+, Multiple Input – Multiple Output Module User Manual



POWER DROPOUT

A periodic Power Dropout status blink (see above table) is shown if the supplied power drops below approx. 11.5 Volts. In addition, the MIMO2+ implements the Alarm/Notification Command Class (Version 2), which provides for a 'power dropout' alarm report to be sent when the supplied power drops. This report is enabled and sent to Node 01 (assumed to be the controller) as the 'factory default' and can be enabled/disabled via the command ALARM_SET_V2. The node sending the ALARM_SET_V2 command is the node to which the MIMO2+ thereafter sends the report. The MIMO2+ sends a 'power applied' alarm report when the supplied power rises above approx. 12 Volts.

TROUBLESHOOTING

The MIMO2+ has been tested with various controllers from other vendors. However, it is not possible to test with every controller on the market. For specific troubleshooting procedures, please refer to your controller instruction manual and/or contact your controller manufacturer. Also, check the FortrezZ, LLC website www.fortrez.com for helpful FAQs and updates to the User Manual / Technical Appendix.

REGULATORY INFORMATION

FCC Compliance Statement Statements

This device complies with Part 15 of the FCC Rules. Operation is subject to the following two conditions:

1. This device may not cause harmful interference, and
2. This device must accept any interference received, including interference that may cause undesired operation. **Contains**

Transmitter Module FCC ID: WRD-FM5202

FCC Warning (Part 15.21). Changes or modifications not expressly approved by the party responsible for compliance could void the user's authority to operate the equipment.

FCC Interference Statement (Part 15.105 (b)). This equipment has been tested and found to comply with the limits for a Class B digital device, pursuant to Part 15 of the FCC Rules. These limits are designed to provide reasonable protection against harmful interference in a residential installation. This equipment generates uses and can radiate radio frequency energy and, if not installed and used in accordance with the instructions, may cause harmful interference to radio communications. However, there is no guarantee that interference will not occur in a particular installation. If this equipment does cause harmful interference to radio or television reception, which can be determined by turning the equipment off and on, the user is encouraged to try to correct the interference by one of the following measures:

- Reorient or relocate the receiving antenna.
- Increase the separation between the equipment and receiver.
- Connect the equipment into an outlet on a circuit different from that to which the receiver is connected.
- Consult the dealer or an experienced radio/TV technician for help.

Industry Canada Statement per Section 4.0 of RSP-100

The term "IC:" before the certification/registration number only signifies that the Industry Canada technical specifications were met.

Section 7.1.5 of RSS-GEN. Operation is subject to the following two conditions: 1) This device may not cause harmful interference, and 2) This device must accept any interference received, including interference that may cause undesired operation.

From section 5.2, RSS-Gen, Issue 2, June 2007 Equipment Labels: **Contains IC: 8156A-FM5202; PN: Model: FM5202-US-SMT**

From section 7.1.6, RSS-Gen, Issue 2, June 2007

Digital Circuits:

If the device contains digital circuitry that is not directly associated with the radio transmitter, the device shall also have to comply with ICES-003, Class A or B as appropriate, except for ICEC-003 labeling requirements. The test data obtained (for the ICES-003 tests) shall be kept by the manufacturer or importer whose name appears on the equipment label, and made available to Industry Canada on request, for as long as the model is being marketed in Canada.

Le présent appareil est conforme aux CNR d'Industrie Canada applicables aux appareils radio exempts de licence. L'exploitation est autorisée aux deux conditions suivantes : (1) l'appareil ne doit pas produire de brouillage, et (2) l'utilisateur de l'appareil doit accepter tout brouillage radioélectrique subi, même si le brouillage est susceptible d'en compromettre le fonctionnement.

Note: Changes or modifications not expressly approved by the party responsible for compliance could void the user's authority to operate the equipment. HELPFUL WEB SITE: Industry Canada <http://www.ic.gc.ca/>

MIMO2+, Multiple Input – Multiple Output Module User Manual



Europe

The MIMO2+ module has been tested for use in European countries. The following testing has been completed:

Test standard EN 300 220 ; (2012-05)

Test standards ETSI EN 301 489-1 ; (2011-09)

A helpful document that can be used as a starting point in understanding the use of short range devices (SRD) in Europe is the European Radio Communications Committee (ERC) Recommendation 70-03 E, downloadable from the European Radio Communications Office (ERO) <http://www.ero.dk>. **The end user is responsible for ensuring compliance with harmonized frequencies and labeling requirements for each country the end device is marketed and sold.** A Declaration of Conformity must be issued for each of these standards and kept on file as described in Annex II of the R&TTE Directive.



The Waste Electrical and Electronic Equipment (WEEE) directive (2002AA/96/EC) was approved by the European Parliament and the Council of the European Union in 2003. This symbol indicates that this product contains electrical and electronic equipment that may include batteries, printed circuit boards, liquid crystal displays or other components that may be subject to local disposal regulations at your location. Please understand these regulations and dispose of this product in a responsible manner.

Limited Warranty

THE PRODUCT IS PROVIDED WITH ONE YEAR LIMITED MANUFACTURER WARRANTY. FORTREZZ, LLC warrants its products to be free from defects in material and workmanship under normal use for one year, and is not responsible for consequential damages or installation costs of any nature. FORTREZZ, LLC. expressly disclaims all implied warranties, including but not limited to the implied warranties of merchantability and fitness for a particular purpose. FORTREZZ, LLC. does not warrant, guarantee, or make any representations regarding the use or the results of the use of the products or any accompanying materials in terms of their correctness, accuracy, reliability or otherwise. In no event shall FORTREZZ, LLC. be liable to Purchaser hereunder or in respect of any products ordered or delivered to Purchaser, whether in contract, tort including negligence or otherwise for a loss of profits or loss of use or for any incidental, consequential, special or indirect damages howsoever caused whether or not FORTREZZ, LLC. has been advised of the possibility of such loss or damage. FORTREZZ, LLC's maximum liability to Purchaser under these conditions shall in no event exceed the amount paid by Purchaser for the products that are the subject of the claim and in respect of all claims for products ordered from FORTREZZ, LLC. to which these conditions apply to the amount paid by Purchaser for the products which are the subject of the claims. If you are not comfortable with your limited warranty, or not completely satisfied with the MIMO, or the MIMO2+ does not perform as expected we encourage you to return the MIMO2+ to your DISTRIBUTOR for an exchange or for a full refund within 30 days of purchase. Or, you can return the MIMO2+ to FORTREZZ, LLC with an RGA number.

All products to be returned to FORTREZZ, LLC. must have a valid Returned Goods Authorization (RGA).

Send the returned unit to: **Fortrezz, LLC Warranty Replacement, 5440 Highway 55, Clover, SC 29710**, postage prepaid with a payment of US\$ 9.95 to cover the cost of return shipping, postage and handling. You must use the original packaging and include a proof of purchase (photocopy of receipt) along with the RGA # and the returned product.